



MSG 95/722

Comfort Seat with Integrated Compressor

To get to your destination without stress, you need safety that won't cost you anything in terms of ergonomics or suspension comfort. For locomotives and self-propelled railway vehicles without an on-board compressed air supply, the MSG 95/722 driver seat with integrated 24V compressor is ideal. The compressor provides excellent operating convenience and suspension comfort at the press of a button, allowing the seat to reliably absorb vibrations and jolts. This safeguards the spine and enhances sitting comfort.



Measurements (installation dimensions)

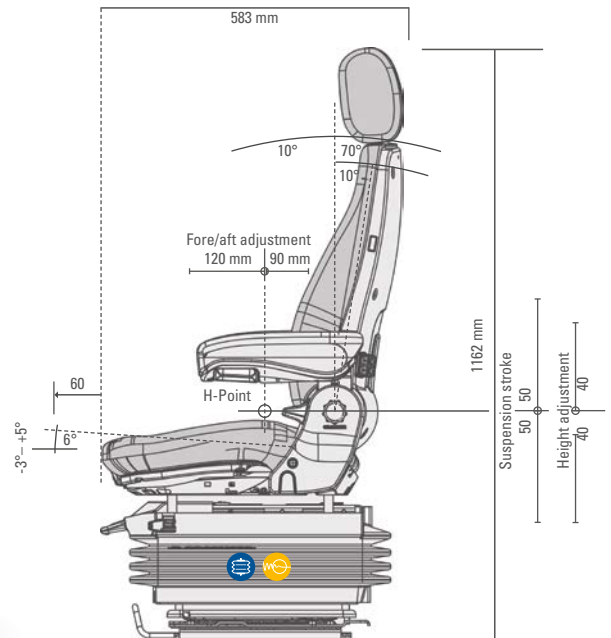
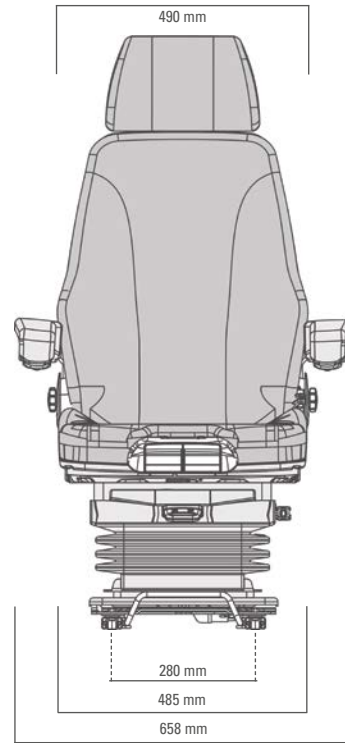

Pneumatic Suspension



Vertical Suspension



Automatic Weight Adjustment



Pneumatic Lumbar Support



Fore/Aft Isolator



Automatic Positioning System