



MSG 90.3

Comfort Seat with Pneumatic Suspension

The MSG 90.3 locomotive driver's seat with pneumatic suspension is equipped with an anti-sinking mechanism. A swiveling mount lets the driver quickly turn the seat for easy operation of the controls.

The pneumatic lumbar support with two independent chambers is infinitely height- and depth-adjustable. The seat cushion length is adjustable to ease strain on the thighs.



Measurements (installation dimensions)

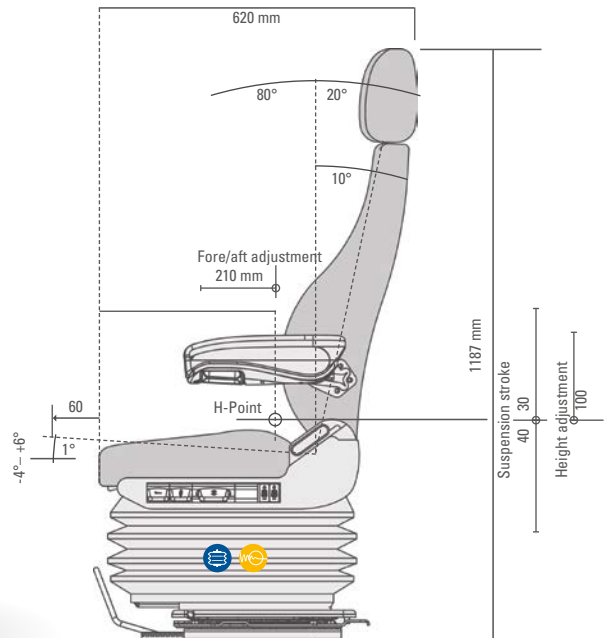
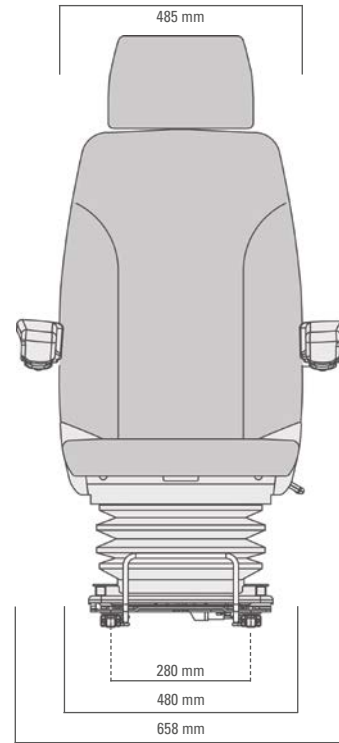

Pneumatic Suspension



Vertical Suspension



Automatic Weight Adjustment



Pneumatic Lumbar Support



Adjustable Shock Absorber



Automatic Positioning System