



# MSG 90.6 LONG

## High-Performance Seat with Pneumatic Suspension

Optimal seat ergonomics crucially improves working conditions and helps preserve the user's health. An example of such an ergonomically mature product is the MSG 90.6 Comfort seat, which has been certified by an independent institute, Landesgewerbeanstalt (LGA) in Nuremberg, Germany, in cooperation with the Ergonomie Institut München (EIM). The seat was examined to determine whether its dimensions and adjustment features are able to accommodate the anthropometric attributes of different users (tall, short, slender, corpulent, etc.). Its ease of use and ability to attenuate vibrations were also thoroughly tested. Based on the results, the seat was awarded the „tested ergonomics“ label.



### Measurements (installation dimensions)

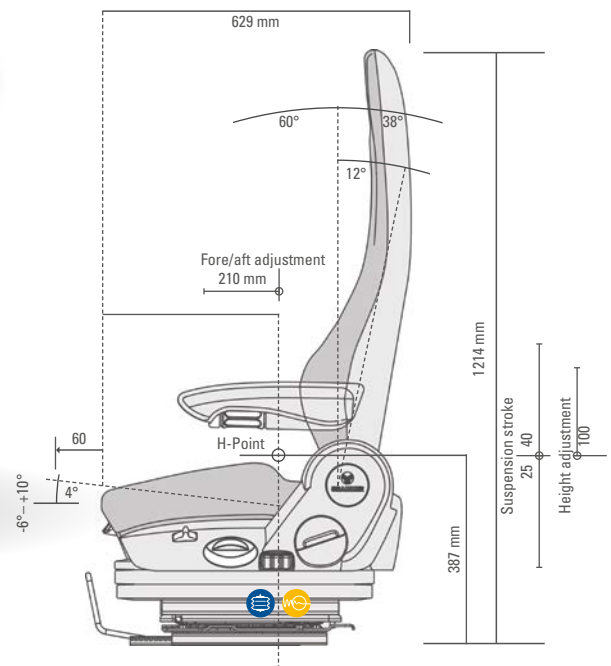
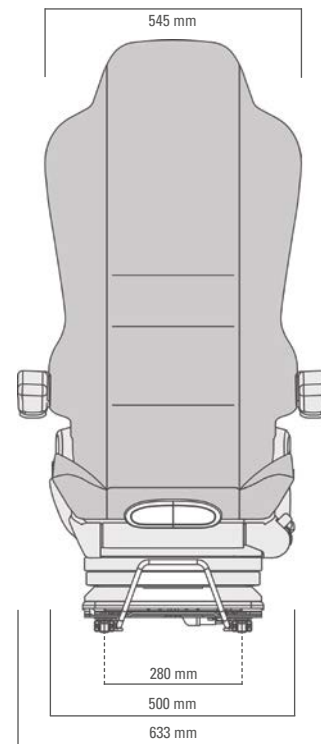

Pneumatic Suspension



Vertical Suspension



Automatic Weight Adjustment



Pneumatic Lumbar Support



Adjustable Shock Absorber



Automatic Positioning System

All dimensions in mm. Subject to technical changes.

The product shown may differ from the standard configuration.